

**300um Discrete pHEMT**

**TGF4350**

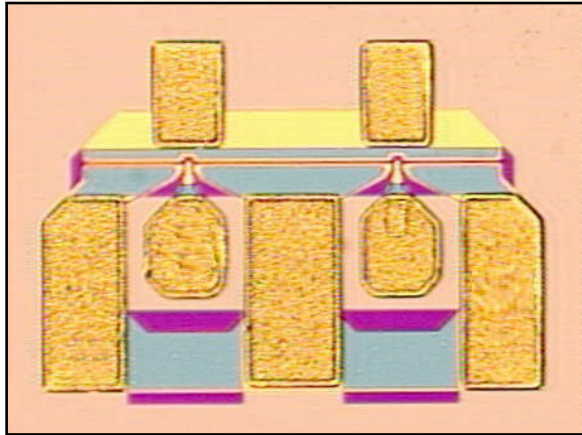

**Key Features and Performance**

- 0.25um pHEMT Technology
- DC 22 GHz Frequency Range
- 1.2 dB NF, 14.5 dB Associated Gain at 10 GHz, 3V Operation
- Floating Source Configuration
- Chip Dimensions 0.620 mm x 0.514 mm

**Primary Applications**

- Low Noise amplifiers

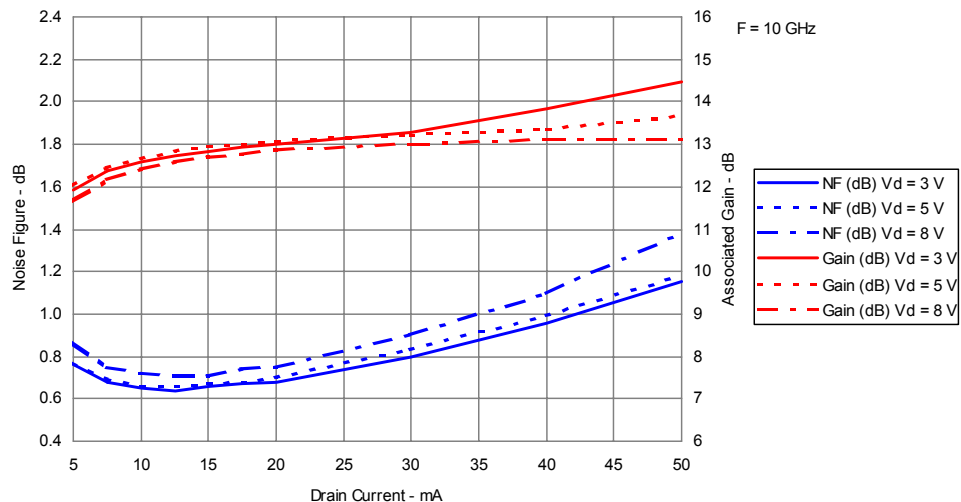
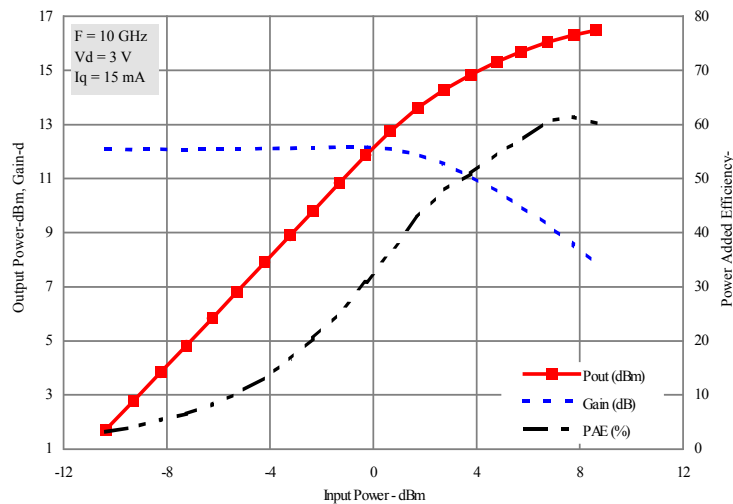

Note: Datasheet is subject to change without notice.

**Electrical Characteristics**

## MAXIMUM RATINGS

Symbol	Parameter	Value	Notes
V <sup>+</sup>	Positive Supply Voltage	13 V	
I <sup>+</sup>	Positive Supply Current	.085 A	<u>3/</u>
I <sup>-</sup>	Negative Gate Current	.88 mA	
P <sub>D</sub>	Power Dissipation	1.1. W	
P <sub>IN</sub>	Input Continuous Wave Power	20 dBm	
T <sub>CH</sub>	Operating Channel Temperature	150 °C	<u>1/</u> , <u>2/</u>
T <sub>M</sub>	Mounting Temperature (30 seconds)	320 °C	
T <sub>STG</sub>	Storage Temperature	-65 °C to 150 °C	

- 1/ These ratings apply to individual FET
- 2/ Junction operating temperature will directly affect the device mean time to failure (MTTF). For maximum life it is recommended that junction temperatures be maintained at the lowest possible levels.
- 3/ Nominal value of Idss

 DC PROBE TESTS  
 (T<sub>A</sub> = 25 °C ± 5°C)

Symbol	Parameter	Minimum	Maximum	Value
Idss	Saturated Drain Current (info only)	30	141	mA
V <sub>P1-5</sub>	Pinch-off Voltage	-1.5	-0.5	V
BV <sub>GS1</sub>	Breakdown Voltage gate-source	-30	-8	V
BV <sub>GD1-5</sub>	Breakdown Voltage gate-drain	-30	-8	V

**FET Elements**

- Lg = 0.040 nH
- Rg = 0.525 Ohms
- Rgs = 14500 Ohms
- Ri = 4.924 Ohms
- Cgs = 0.364 pF
- Cdg = 0.042 pF
- Rdg = 146000 Ohms
- Rs = 0.300 Ohms
- Ls = 0.041 nH
- Rds = 253.858 Ohms
- Cds = 0.080 pF
- Rd = 0.833 Ohms
- Ld = 0.028 nH
- VCCS Parameters
- M = 0.091 S
- A = 0
- R1 = 1E19 Ohms
- R2 = 1E19 Ohms
- F = 0
- T = 4.000 pS

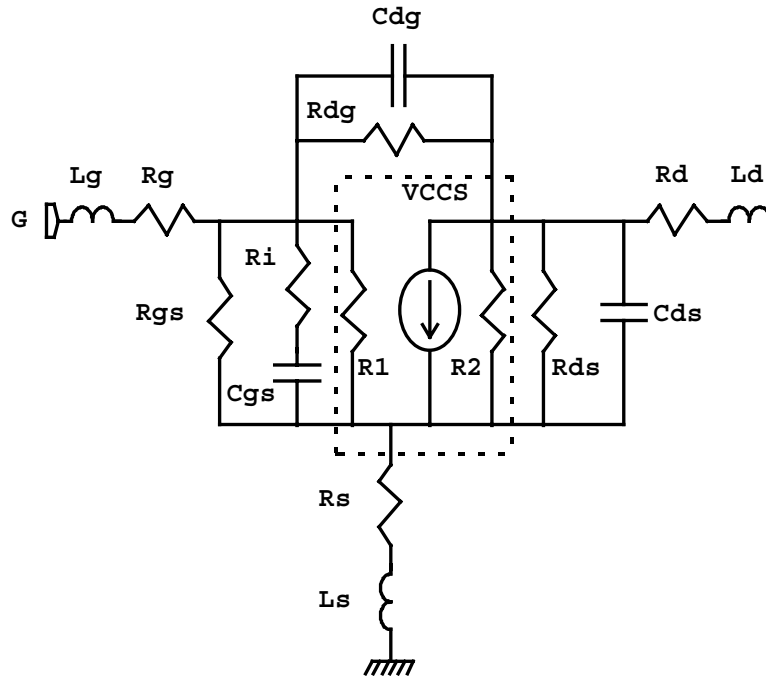

TGF4350 pHEMT Model (Vds = 3.0 V and 15mA at T = 25°C)

Device is mounted on a 20 mil high ledge. Source inductance includes that of source bondwires and ledge

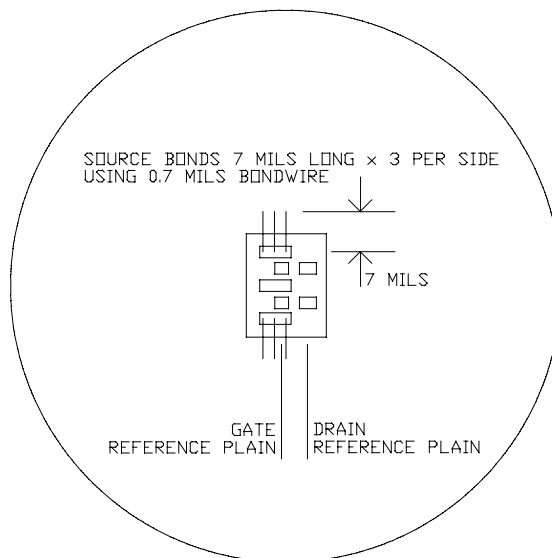

**Mechanical Drawing**

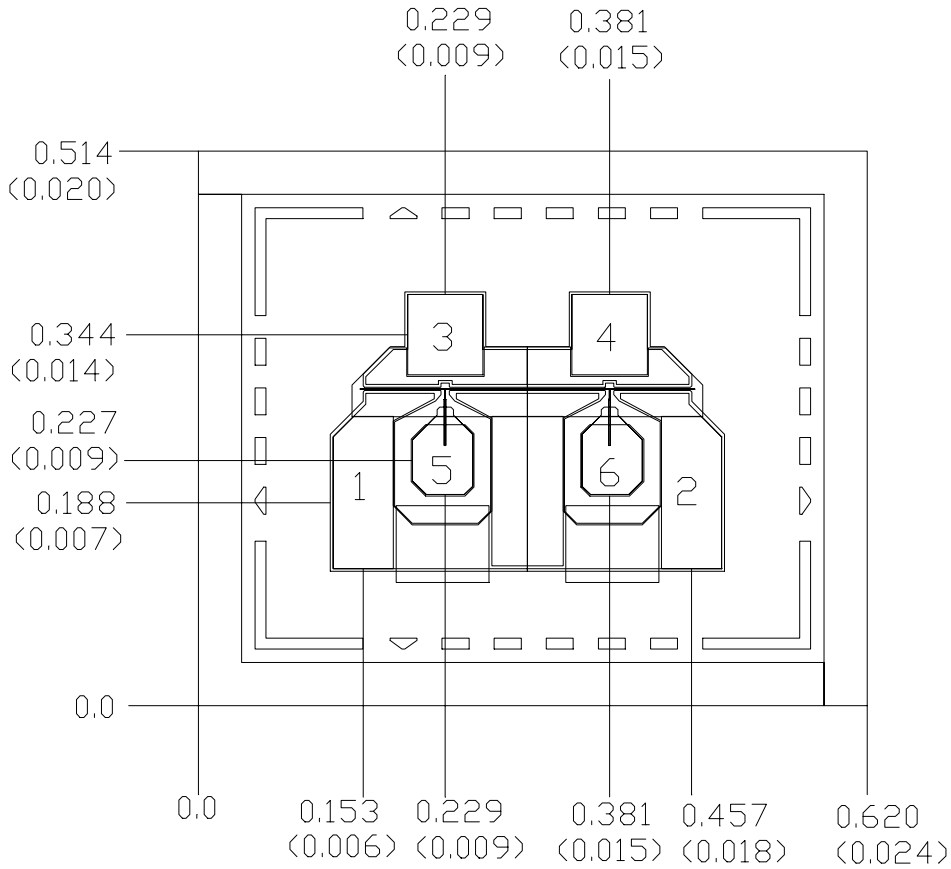

Units: millimeters (inches)

Thickness: 0.1016 (0.004)

Chip edge to bond pad dimensions are shown to center of bond pad

Chip size tolerance: +/- 0.051 (0.002)

Bond Pad #1,#2 (Source) 0.056 x 0.123 (0.002 x 0.005)

Bond Pad #3,#4 (Drain) 0.070 x 0.074 (0.003 x 0.003)

Bond Pad #5,#6 (Gate) 0.056 x 0.065 (0.002 x 0.003)

## Process and Assembly Notes

***This device can be attached using conductive epoxy or AuSn solder.***

### Reflow process assembly notes:

- AuSn (80/20) solder with limited exposure to temperatures at or above 300°C
- alloy station or conveyor furnace with reducing atmosphere
- no fluxes should be utilized
- coefficient of thermal expansion matching is critical for long-term reliability
- storage in dry nitrogen atmosphere

### Component placement and adhesive attachment assembly notes:

- vacuum pencils and/or vacuum collets preferred method of pick up
- avoidance of air bridges during placement
- force impact critical during auto placement
- organic attachment can be used in low-power applications
- curing should be done in a convection oven; proper exhaust is a safety concern
- microwave or radiant curing should not be used because of differential heating
- coefficient of thermal expansion matching is critical

### Interconnect process assembly notes:

- thermosonic ball bonding is the preferred interconnect technique
- force, time, and ultrasonics are critical parameters
- aluminum wire should not be used
- discrete FET devices with small pad sizes should be bonded with 0.0007-inch wire
- maximum stage temperature: 200°C

***GaAs MMIC devices are susceptible to damage from Electrostatic Discharge. Proper precautions should be observed during handling, assembly and test.***